



## **AOW-S400 & AOW-S500**

### Residential Water Softener Systems

- Designed, engineered and built to last
- Patented, slim, single-unit design with bypass valve
- S400: 34.800 Grain Capacity, S500: 49.800 Grain Capacity
- S400: for 1-2½ bathroom homes, S500: for 3-5 bathroom homes
- Get peace of mind with our limited warranty
- No sediment filter changes - ever
- Power loss protection
- Backup battery saves your settings in case of power loss
- Fast and quiet regeneration
- Recharges softening media quickly so you don't experience downtime
- Modify settings with 2.7" monochrome touchscreen controller

Designed for durability - protect your home from the effects of hard water, Reduce scale build-up, eliminate water spots and stains, and extend the life of your appliances and preserve the colors in your favorite fabrics.

Flow Rate	Grain Capacity	Min Pressure	Max Pressure	Min Temp	Max Temp	Inlet / Outlet	Certification numbers	Certifier	Max Iron Rating	Salt Storage
7 GPM (6,44 L/min)	<b>S400</b> 34.800	20 psi (1.4 bar)	120 psi (8.3 bar)	40° F (4° C)	120° F (49° C)	1" MIP	44	NSF/ANSI	10 parts per million	200 lbs
	<b>S500</b> 49.800									

### Warranty

Complete Unit	Electronics	Valve	Media Tank and Cabinet
1 yr	3 yr	6 yr	12 yr

### Dimensions

S400

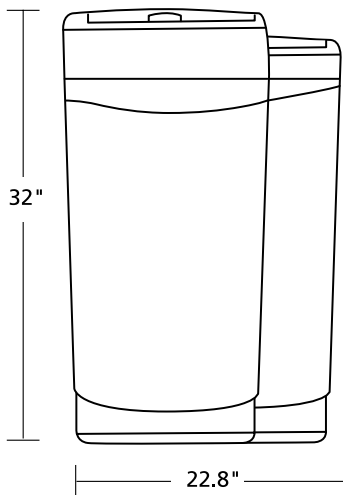

S500

